

THE VILLAGE HUG



Connecting Community Creatively

Issue 7 – 29th May 2020

*“Come to me, all of you who are weary and carry heavy burdens, and I will give you rest.”
Matthew Chapter 11, Verse 28*

The Village Hug is a weekly newsletter created by the young folk of Torrance Parish Church as a gift to the people of Torrance during the Coronavirus Emergency.

Please pass on this PDF to others who may enjoy it and print it off for people not connected by email or Facebook (whilst taking the appropriate social distancing precautions of course).

If you have any ideas for future content then please contact us at thevillagehug@gmail.com

INTERVIEW with Jamie Stone by Cameron MacLeod

For this issue we were lucky enough to grab an interview with Jamie Stone, a filmmaker who recently spearheaded the latest series of *Doctor Who*. He directed the two-part series opener, which screened to much acclaim on New Year’s Day, and the series finale.

Although he may now be heading major projects down in London and Cardiff, Jamie was brought up in Torrance and attended the local primary school. With his father Norman also being a filmmaker, it’s little wonder that Jamie began to gain an interest in the world of film too. He soon began his path into the creative industries himself making short films around his house with a video camera and the help of his friends.

These home videos set him on the path to study Film and Television at The Edinburgh College of Art and then to study directing at the prestigious National Film and Television School in London. Here he directed the short films *Skyborn* and *Orbit Ever After* -starring Mackenzie Crook (The Office and The Detectorists) and young Thomas Brodie-Sangster (Love Actually).

You can watch these ‘shorts’ on the links on this page. In these student films you can see the sense of fun, wonder and melancholy that Jamie can create. This gift along with his love of ‘in-camera’ effects – *i.e.* real (not digital) special effects – are presumably what drew the producers of Sky One’s Christmas Day fantasy drama *The Last Dragon Slayer* to hire him to direct their show in 2016.

Jamie’s influence on his peers can be seen in *Worzel Gummidge* which aired on Boxing Day 2019 on BBC1. It was written and directed by Mackenzie Crook and displays the physical effects and wonderment that Jamie’s work exudes.

In 2019 the Dr. Who producers turned to Jamie as they looked to re-boot their flagship BBC 1 series by taking it ‘back-to-basics’ with simpler storylines and a real sense of fun and adventure.

Jamie enjoys the challenges and thrills of working on set as a television director. The quick schedules and unforeseen challenges can be what makes the job fun. He’s in no doubt that he’s lucky to have Jodi Whittaker as ‘his Doctor’ as she loves to work fast and think practically on how to make the scene work.

He’s come along way since making home videos in Torrance and is hopeful he, and Dr. Who, will return for another series!



Skyborn:

https://www.youtube.com/watch?v=kLDa7AI_Mp0

Orbit Ever After:

<https://www.youtube.com/watch?v=DpFXMIxlgPo>

NATURE WALK *by The Thomson Family*

If you're looking for a walk or cycle route with some beautiful nature, then head to the Forth and Clyde Canal just now! There are cygnets and ducklings to see in the spring sunshine.

Head out of the village up Torrance Road and join the canal pathway. It's a steep climb, but at least you can take comfort from the fact that it will be downhill on the return journey.

Follow the canal pathway towards Kirkintilloch and walk all the way to the new V-shaped pedestrian bridge.



Cross the bridge. From the 'point' of the bridge you'll see the swans' nest beside the new primary school building. It's worth looking at the marina which is located on the south side of the bridge while you are here.

If the swans are not near their nest, then return to the path on the north side of the canal and keep going east. You may find them near St Mary's church or even as far as Hillhead Basin, but it will be well worth the search. There are nine cygnets with the adult pair of swans and a similar number of ducklings with lots of excitable ducks!

Always remember, please don't be tempted to feed the ducks or the swans and stay safe near the water's edge.



The Fault in our Stars (2014)– Cert 12A – Film4, Fri 29th May, 6:25pm

Shailene Woodley and Ansel Elgort star in this romantic drama about two cancer-afflicted teenagers who fall in love and make plans to visit Europe. Also starring Willem Dafoe, Laura Dern and Sam Trammell.

4/5 Village Hugs



Central Intelligence (2016) – Cert 12A – Film4, Fri 29th May, 9pm

Calvin, a mild-mannered accountant, is dragged into a world of espionage by his old high-school buddy, Bob, who is now a CIA agent. With both their lives at risk, they must team up to stop a terrorist plot. Comedy/Action Adventure with Dwayne Johnson and Kevin Hart.

3/5 Village Hugs

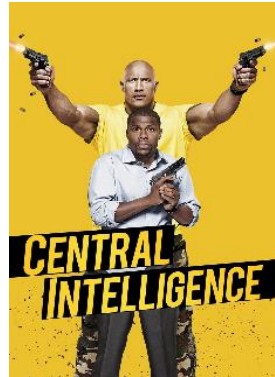

Stranger Than Fiction (2006) – Cert 12 – Sony Movies, Sun 31st May, 3:35am

Harold Crick, an I.R.S. Auditor, suddenly begins to hear a voice inside his head, narrating his entire life, which will affect his work, his love-life and his death. Comedy drama starring Will Ferrell and Emma Thompson.

4/5 Village Hugs

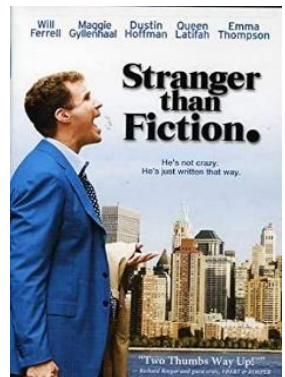

The Simpsons Movie (2007) – Cert PG – Film4, Sun 31st May, 7:15pm

When Homer's love for a pig causes him to pollute Lake Springfield, he and the family are declared fugitives and must escape from the town which has been placed under a massive dome by the villainous Environmental Protection Agency (EPA). Will Homer decide to do the right thing and return to save his family, his town and his neighbours? Animated comedy with the voices of Dan Castellaneta, Nancy Cartwright and Albert Brooks.

4/5 Village Hugs



Prime Numbers and Eratosthenes

Whole numbers come in two types – special numbers and ordinary numbers (1 is a special case and we'll ignore that just now!). Every ordinary number can be made by multiplying the special numbers together. The proper name for these special numbers is Prime Numbers. Primes can't be made by multiplying other numbers together.

We use prime numbers for all sorts of things in maths. One really useful thing is that our bank accounts are kept safe when we buy online by codes that use very big prime numbers.

Eratosthenes was an incredibly intelligent man who lived in North Africa about 2,200 years ago. He was the first man to work out the size of the Earth correctly. He used the angle you had to move your head through to look up at the sun and the distance you were away from a well that the sun was shining directly into (I said he was in Africa) to do it

He also invented this way of finding which numbers were prime – why not try it for yourself?

Just as a sieve in your kitchen holds your pasta and lets the water dribble through, this holds onto the prime numbers and lets the ordinary numbers go.

1. Cross out 1 (I said we'd ignore it just now).

2. Circle the 2. Cross out all the numbers that are in the 2 times table. Keep going all the way to 100. These are the multiples of 2.

3. Circle the 3. Cross out the multiples of 3.

4. Circle the next uncrossed number. Cross out its multiples.

5. Keep doing this until every number in the grid is circled or crossed.

1	2	3	4	5	6	7	8	9	10
11	12	13	14	15	16	17	18	19	20
21	22	23	24	25	26	27	28	29	30
31	32	33	34	35	36	37	38	39	40
41	42	43	44	45	46	47	48	49	50
51	52	53	54	55	56	57	58	59	60
61	62	63	64	65	66	67	68	69	70
71	72	73	74	75	76	77	78	79	80
81	82	83	84	85	86	87	88	89	90
91	92	93	94	95	96	97	98	99	100

The circled numbers are the prime numbers up to 100. You should have 25 of them.

MASQUERADE – ANSWERS FROM ISSUE 6

1. Lulu.
2. Lewis Capaldi (he came onto stage at the 2019 TRNSMT festival in a Wookie mask).
3. Peter Howson. He is the person who previously lived in Torrance.
4. Karen Gillan.
5. Mary Queen of Scots.
6. Sir Tom Hunter.

"Dear Lord

We pray for those who are battling coronavirus right now or recovering from it. We ask for complete healing for them and comfort for their family members and friends .

We thank you for all the health care workers in different areas of the NHS at this time and pray for protection for them as they carry out their duties and that their families at home will be protected.

We also give you thanks for all those in the community who are providing practical help and care to their neighbours and others in the village. We ask that you would help us to be aware of those around us who might need help.

Amen"

Are you in need of help, prayer, to be listened to in confidence?

Please don't hesitate to contact the following number by phone call, WhatsApp or text:

07788 797238

This is a dedicated phone number, used only by the Prayer Ministry Team.

Invitation - Let's connect!

Invitation to the Alpha Course in Torrance.

Would you like to participate in an online Alpha course?

With everyone so isolated we thought it would be good to connect with others in the community, to grab this rare opportunity to find time, to think and talk about the big questions of life (Is this all there is? Why am I here?); about faith and reason and God and meaning. This is intended as an open, honest and informal space where hard questions, deep questions or just chat are all welcome.

We are running an online version of a course called **Alpha** that millions all round the world have done over the last 30 years.

It will be run over Zoom, on Monday evenings from 1 June at 7.30pm.

No membership, no follow up calls, no charge, no need to speak, just a chance over 11 weeks to explore the big questions about the Christian faith and hear other people's views!

The evenings start with a video talk of about 20 minutes on a subject, which will be followed by open discussion on Zoom for around 45 minutes.

Why not check it out with this one and half minute series trailer?

Just click on the link (or copy it down and enter it into your internet browser):

<https://player.vimeo.com/video/357618357>

We would be really delighted if you would join us.

If you would like to, please contact Geoff Burns at geoffburns@barnellan.org.uk or on 01360 620220.



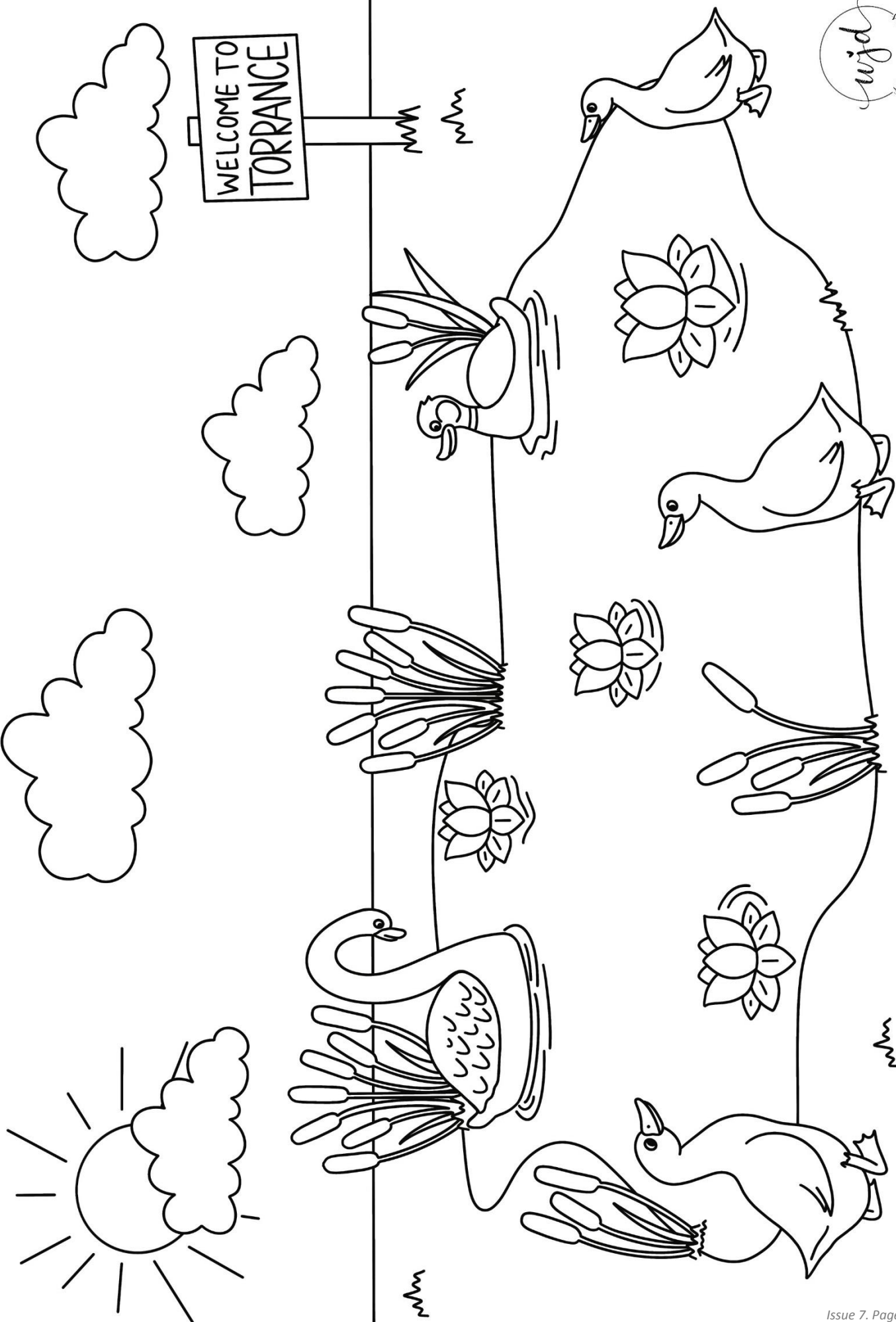

WOODEN PLANTER *by the Lunan Family*

This is a great project for using up reasonably sized scrap lengths of wood. Although this guidance recommends sizes these can be changed to suit your materials and the space you have in your garden. We used left over lengths of decking and old pallets.



Stage 1

Collect the following tools: pencil, try square 9 (if you have one), power drill / power screw driver, saw, 3-4mm twist drill bit, flat drill bit or other large diameter drill bit 10-30mm. You will also need wood screws suitable for outdoor use – approximately 5x50mm. Other items that are useful if you intend to use the planter straight away are scissors, wood stain, plastic sheeting, stones and compost.



Stage 2

Mark out the timber using the drawings below and cut to length with the saw.



Adjust the design to suit your needs but some features should be kept as they are important:

-the feet: it is important that the base of the planter is raised above the ground

-the drainage holes: you have to ensure that your plants will not drown in a heavy shower. See photo of Tom piercing the plastic.

-pilot holes. These will ensure that the wood does not split when joining parts with the screws. See photo of Rachel drilling.



Stage 3

Paint with a preservative. The one we had was one with a stain finish.



Stage 4

Line the trough with the pierced plastic, then add a layer of stones. Finally, add compost and then plants.



ASSEMBLED PLANTER

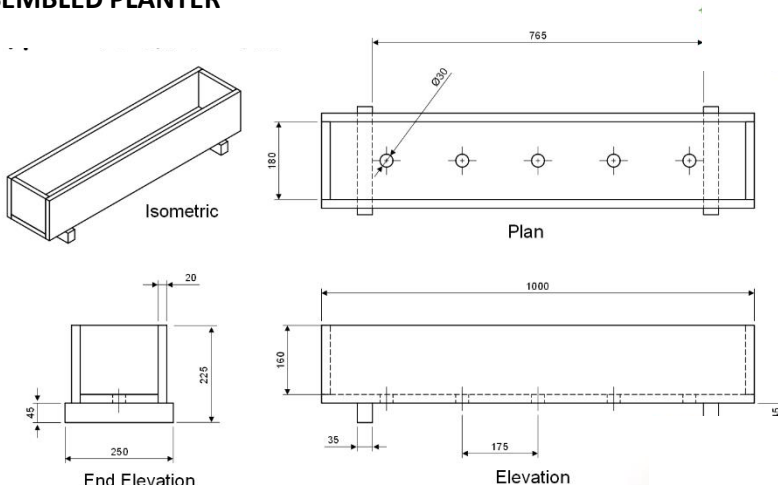

SIDE OF PLANTER

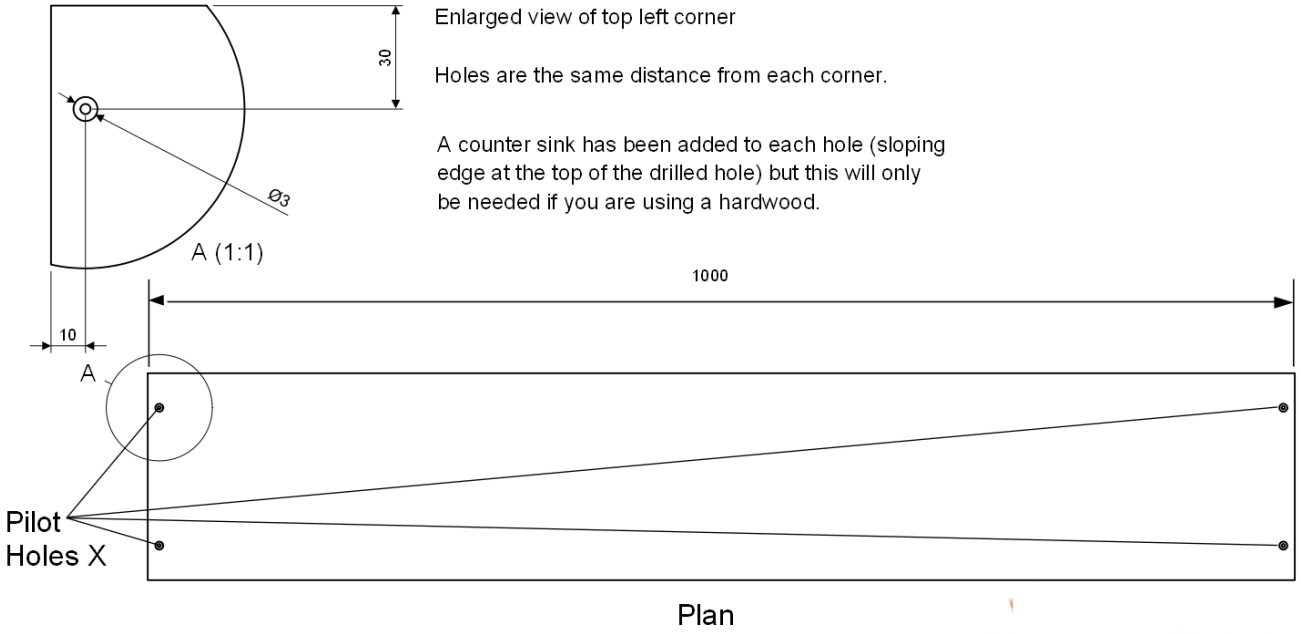

BASE OF PLANTER

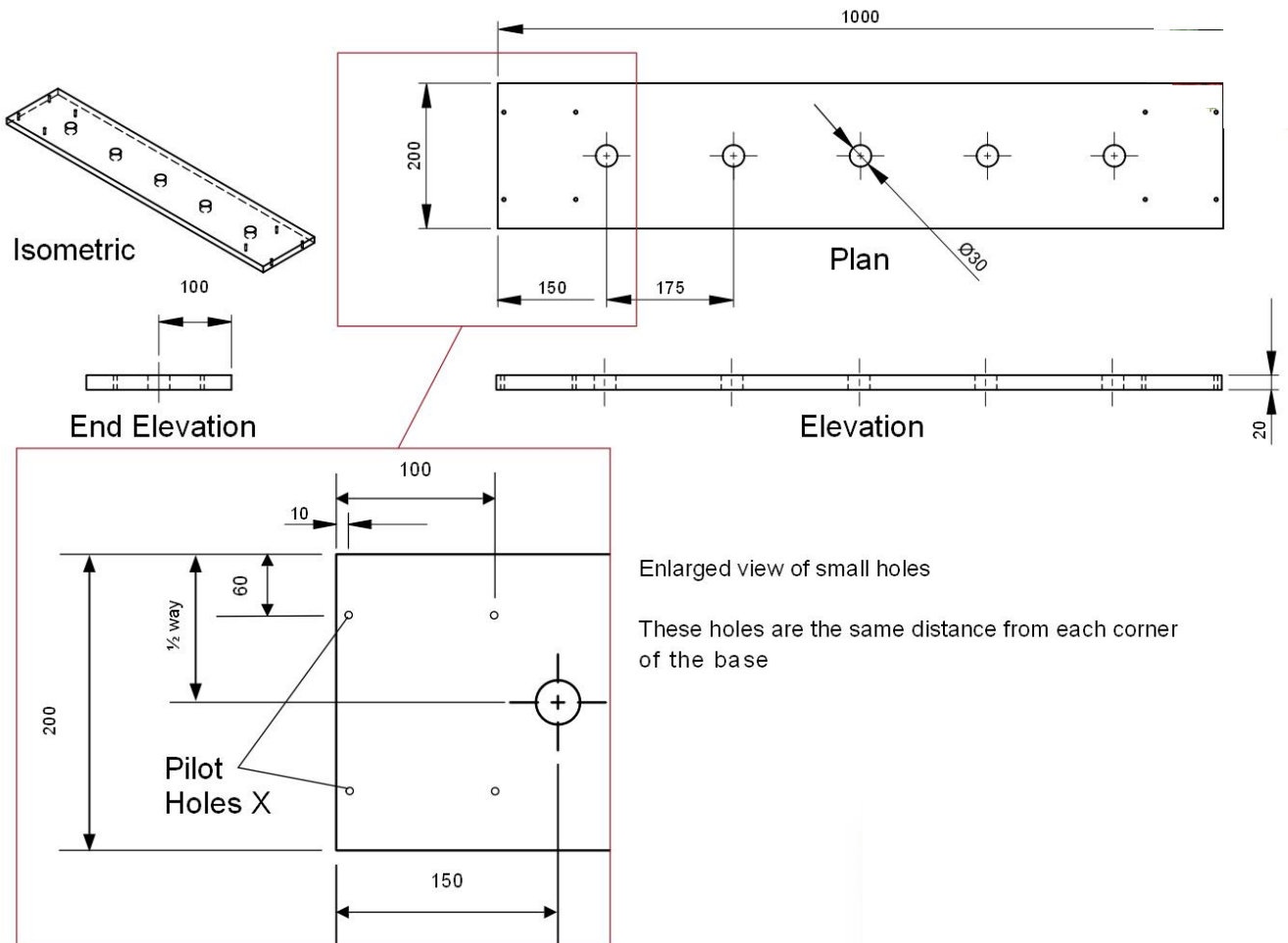

Christians Against Poverty (CAP)

The Kirkintilloch branch of CAP has restarted our free debt counselling services.

Originally all services were delivered by visits to clients' homes; however for the current situation with coronavirus we have re-aligned our services to deliver by telephone, with the approval of the FCA.

If you find yourself in a situation of uncontrollable, unmanageable debt, please contact our head office freephone number, 0800 328 0006 to schedule a telephone appointment.

If you have an urgent immediate need, please contact me on my mobile: 07881 302398.

Colin Richards, Kirkintilloch Manager, CAP



SOCIAL DISTANCING

As we're all aware by now, when we're outside our houses and close to anyone from outwith our households we have to enact 'social distancing'. This means we need to stay two metres away from each other. Here's a couple of handy Village Hug tips for practising good social distancing:

1. The phrase '*social distancing*' has a negative emphasis... why not turn this around in your head into something positive and call it '*conscious uncrowding*' ©Gwyneth Paltrow.
2. Many people find it difficult to visualise what two metres looks like in the real terms. These should help!

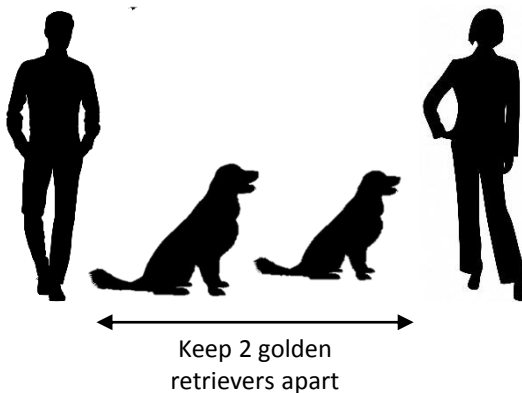
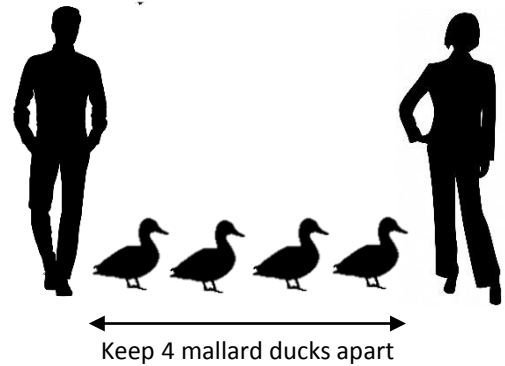
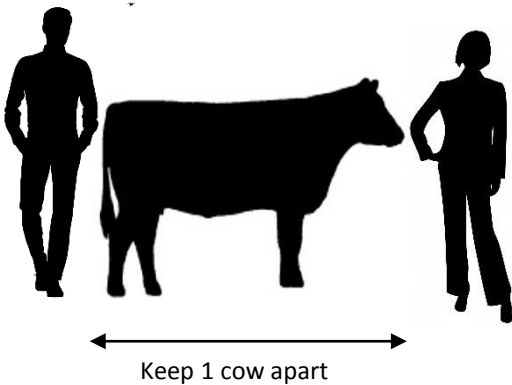

CARROT CAKE RECIPE *from Susan Leung*

Ingredients:

- 175g golden caster sugar
- 175mls sunflower oil
- 3 large free-range eggs
- 1 large carrot – finely grated
- 2 handfuls of raisins
- 175g self raising flour
- 1tsp bicarbonate of soda
- 1tsp cinnamon
- 1/2 tsp nutmeg
- 1 large tub full fat Philadelphia cheese
- 3 tblsp icing sugar
- 1 drop of vanilla

Method:

1. Mix the caster sugar and sunflower oil together well.
2. Add the 3 eggs, finely-grated carrot and raisins then mix well.
3. Sift the flour, bicarbonate of soda, cinnamon and nutmeg into the mixture and stir well.
4. Bake at 160°C in a fan oven for 45 minutes then check the middle has baked using a skewer.
5. Mix the Philadelphia cheese, icing sugar and vanilla. Check the mix is sweet enough.
6. Spread the topping once the sponge has cooled, allowing it to run over the edges.

Do you have a great recipe worth sharing with the Village?

-Send it to thevillagehug@gmail.com



SUNDAY SERVICE AT 10:30AM EVERY WEEK

During the Coronavirus Emergency you can listen to and watch the service using the Zoom webinar conferencing app. You'll be able to see the song words and the people leading the service. As a viewer you won't be visible on screen.

<https://zoom.us/j/462751387>

The Meeting ID is: 462 751 387.

OFFICE Email office@tpc.org.uk Phone 01360 620 970
Website <http://www.torranceparishchurch.org.uk/>



@torrancechurch



Facebook.com/
torrancechurch

**torrance
parish
church**

